



# Butler Matrix (MA8114A/MA8118A)



# About MA8114A/MA8118A

MA8114A/MA8118A is a passive device and has a built-in **Butler Matrix circuit**. Even if signal is input from any of input ports, it will be distributed equally to the output ports, and the phase shift of those output ports will differ depending on the input port. The MA8114A has 4 input ports x 4 output ports, the MA8118A has 8 input ports x 8 output ports.

→ Propagation path that can be reproduced by cable connection  
→ Propagation path that cannot be reproduced by cable connection

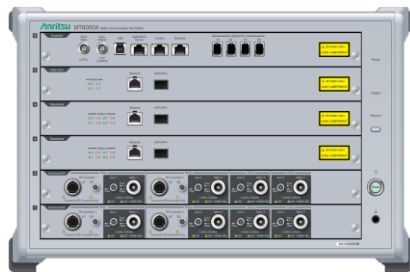

or

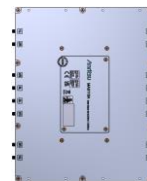
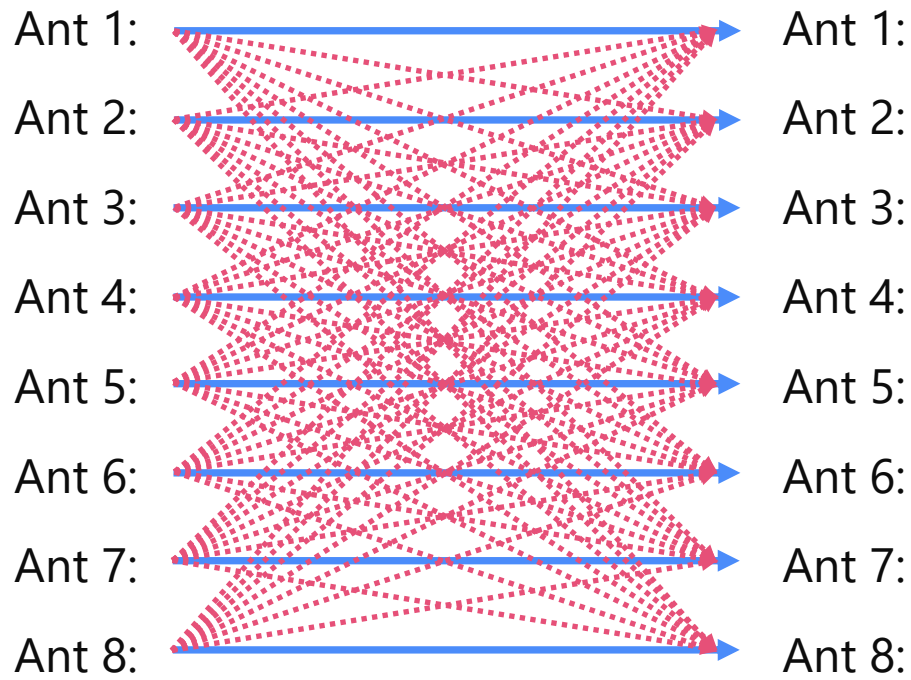

- To facilitate the verification of 4x4 MIMO Throughput in **base station testing for Operators** and **WLAN vendors' Wi-Fi AP - Device** 4x4 MIMO Throughput verification with easily and cost-effectively, a 4x4 Butler Matrix is adopted in the market.
- 3GPP Release 17 has extended the FR1 frequency up to 7.125GHz. Also, with the addition of the 6 GHz band (5.925 – 7.125 GHz) from Wi-Fi 6E, **it is anticipated that testing of the new frequency bands will be required in near future.** Butler Matrix(MA8114A/MA8118A) can support the extended frequency band.

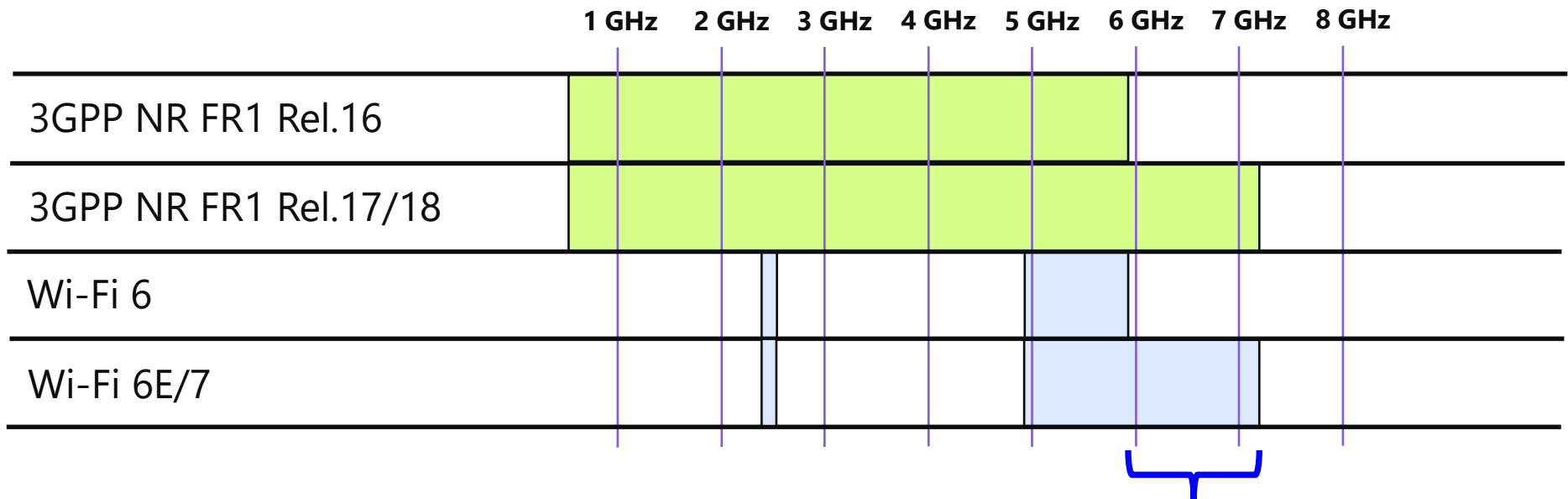

Extended frequency band.  
It can be supported by MA8114A/MA8118A

MA8114A

Butler Matrix 4x4

(0.6GHz-7.125GHz)

Especially for Base Station/Wi-Fi AP vendors, there is a difficulty for evaluating MIMO Throughput for the following reasons:

- ❑ Poor test result reproducibility by OTA Connection in Shield Environment
- ❑ Difficult to realize MIMO propagation path by RF cable+Combiner connection environment

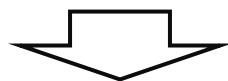

Anritsu MIMO Throughput Solution can address the issues by providing Butler Matrix RF combiner

- ✓ Good test result reproducibility
- ✓ Easily establish MIMO propagation path

## Solution

**MA8114A :**  
**600 MHz – 7.125 GHz**



**Released at 2024.Mar.**

# Advantages of Using Butler Matrix

- ✓ Base Station/Wi-Fi AP vendors need 4x4 MIMO throughput evaluation
- ✓ **MA8114A is better solution that can support it easily and at low cost.**

## OTA Connection in Shield Environment:

- ✓ **Poor test result reproducibility** because the environment changes depending on the location.



## RF Cable + Combiner Combinations :

- ✓ **Can't support 4x4 MIMO testing** because all signals are mixed by RF combiners



**RF Combiner Combinations can't be used**

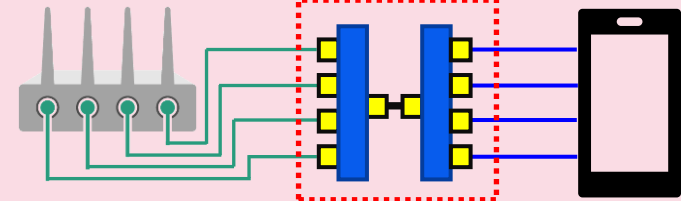

## Butler Matrix (MA8114A) :

- ✓ **Good test result reproducibility** by RF cable connection
- ✓ **Support 4x4 MIMO testing** because MA8114A can divide all signals



**MA8118A can be also available especially for 8x8 MIMO testing case**

# MA8114A Specification

Spec. Item	Unit	Anritsu Butler Matrix 4x4 (0.6GHz-7.125GHz) MA8114A			
Frequency Range	GHz	0.6 to 0.7	0.7 to 4.2	4.2 to 6.0	6.0 to 7.125
VSWR	Max.	1.8	1.8	2.1	2.4
Insertion Loss	dB Max.	10	10.5	11.5	12.5
Amplitude Balance	dB Max.	5.0	3.7	3.7	5.0
Phase Balance	deg Max.	+/- 30	+/- 20	+/- 20	+/- 30
Isolation	dB Min.	15 Nom.	15 Nom.	15 Nom.	15 Nom.
Max. RF Input Power	dBm	+30			
Impedance	$\Omega$	50 Nom.			
Connectors	-	SMA Female			
Dimension (WxHxD)	mm	236.6 x 135.2 x 12			
Mass	Kg	1.0			
Operating Temp.	$^{\circ}\text{C}$	5 to 40			

MA8118A

Butler Matrix 8x8

(0.6GHz-7.125GHz)

NR FR1 testing needs RF cable re-cabling during testing many times for the following reasons:

- ❑ Many RF ports on DUT as higher MIMO and multiple bands
- ❑ Cabling from/to test equipment is becoming more complex

It makes difficult to realize test automation. In addition, this causes test failures unless cabling is properly set up

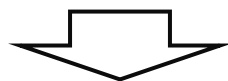

Anritsu FR1 Conducted Solution can address the issues by providing Butler Matrix RF combiner

- ✓ Reduce re-cabling as Butler Matrix handles all RF paths
- ✓ Fit for MIMO Throughput testing

## Solution

**MA8118A :**  
**600 MHz – 7.125 GHz**



**Released at 2023.Sep.**

# Advantages of Using MA8118A

- ✓ 5G NSA/SA UE supports **100+ band combination** including **MIMO conditions**
- ✓ **MA8118A is better solution to test it by reducing re-cabling**

## Direct RF Cable Link :

- ✓ **Needs re-cabling many times** for testing UE's all band combinations

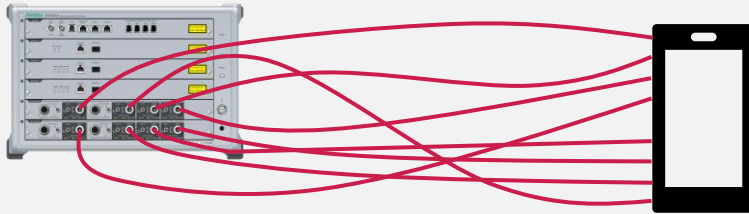

## RF Combiner Combinations :

- ✓ **Can't support MIMO testing** because all signals are mixed by RF combiners



**RF Combiner Combinations can't be used**

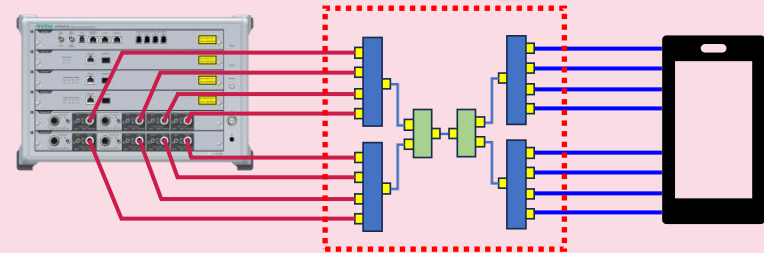

## Butler Matrix (MA8118A) :

- ✓ **Only a few re-cabling is needed** for testing UE's all band combinations
- ✓ **Support MIMO testing** because it can divide all signals

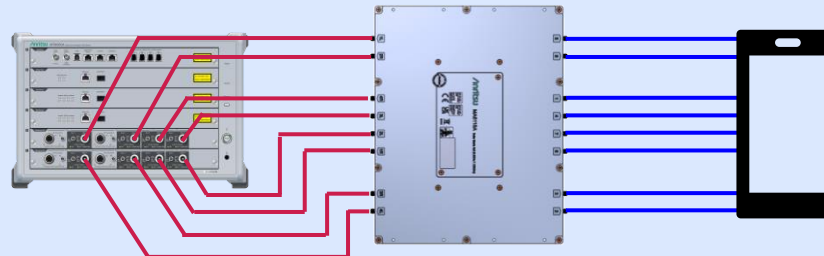

# MA8118A Specification

Spec. Item	Unit	Anritsu Butler Matrix 8x8 (0.6GHz-7.125GHz) MA8118A				
		0.6 to 0.7	0.7 to 2.7	2.7 to 4.2	4.2 to 6.0	6.0 to 7.125
Frequency Range	GHz	0.6 to 0.7	0.7 to 2.7	2.7 to 4.2	4.2 to 6.0	6.0 to 7.125
VSWR	Typ.	1.3	1.3	1.3	1.3	1.3
	Max.	2.0	2.0	2.0	2.3	2.7
Insertion Loss	dB Typ.	12	12	13	14	15
	dB Max.	16	16	17	18	19
Amplitude Balance	dB Typ.	4.0	2.0	2.0	2.0	2.0
	dB Max.	6.5	6.0	5.0	5.0	6.0
Phase Balance	deg Typ.	+/- 10	+/- 5	+/- 5	+/- 10	+/- 15
	deg Max.	+/- 30	+/- 20	+/- 20	+/- 30	+/- 30
Isolation	dB Typ.	20	20	20	20	20
	dB Min.	14 Nom.	14 Nom.	14 Nom.	14 Nom.	14 Nom.
Max. RF Input Power	dBm	+30				
Impedance	$\Omega$	50 Nom.				
Connectors	-	SMA Female				
Dimension (WxHxD)	mm	310 x 244 x 17.5				
Mass	Kg	4.0				
Operating Temp.	°C	5 to 40				

**Note** : "Typ." Means typical value. It is not guaranteed value.

# Use Case : DL Max Throughput Testing

## ENDC case

→ When test condition meets slide7 (total loss is under 25 dB), DL Max Throughput testing can be supported

MT8000A with 033 module



MT8821C



- ① 0.5 m RF Cable loss (\*1) : 0.58 dB @7 GHz
- ② 1.0 m RF Cable loss (\*2) : 1.60 dB @7 GHz
- ③ Combiner Loss (\*3): 3.50 dB @7 GHz
- ④ MA8118A Insertion loss : 19.0 dB @7 GHz

Total loss for **Route1 (Combiner route)**:

$$\rightarrow \textcircled{1} + \textcircled{3} + \textcircled{1} + \textcircled{4} + \textcircled{1}$$

$$= 0.58 + 3.5 + 0.58 + 19 + 0.58 = 24.24 < 25 \text{ dB}$$

Total loss for **Route2 (no combiner route)** :

$$\rightarrow \textcircled{2} + \textcircled{4} + \textcircled{1}$$

$$= 1.6 + 19 + 0.58 = 21.18 < 25 \text{ dB}$$



Max Throughput testing can be supported

- (\*1) : Mini-Circuits CBL-0.5M-SMSM+
- (\*2) : Mini-Circuits CBL-1M-SMSM+
- (\*3) : Mini-Circuits ZN2PD-183W-S+

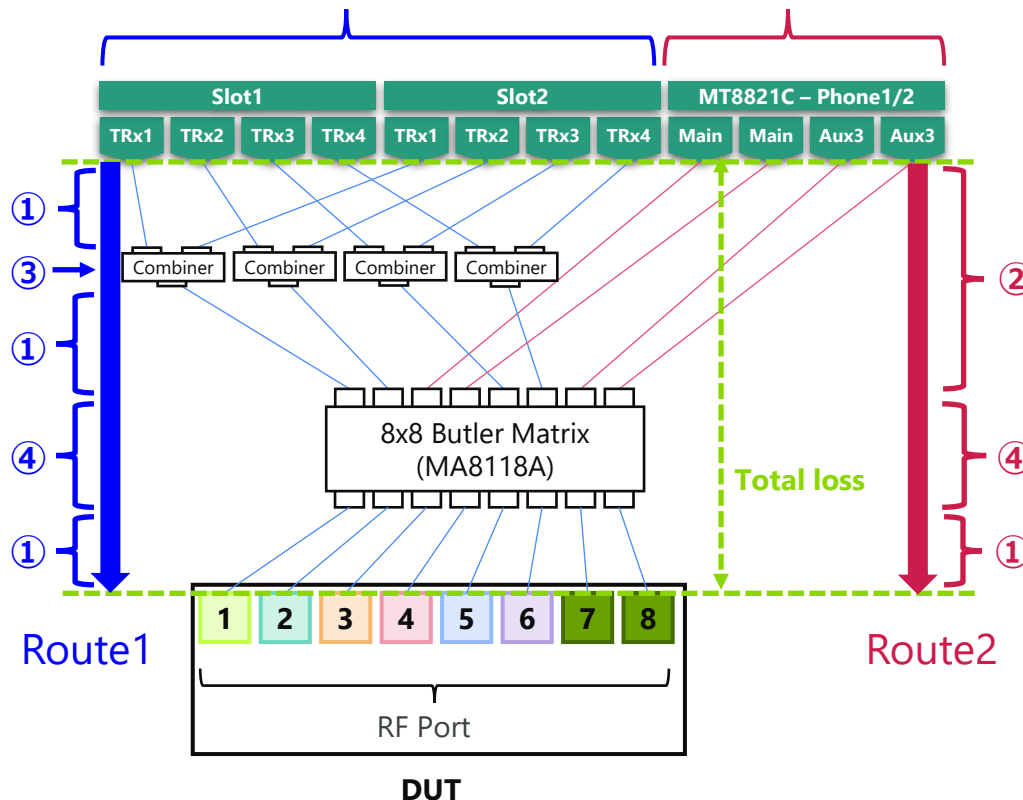

# Acceptable Total Loss for DL Max Throughput Testing

For the following test condition, when total loss is under 25 dB, there is 34 dB or more SNR. That means DL Max Throughput testing can be supported.

Required SNR for 256QAM DL Max Throughput :	34 dB	
Signal MT8000A DL Level :	-89.91 dBm/Hz	Main port max. output level : -10 dBm (CBW100 MHz)
Noise DUT total noise level:	-148.91 dBm/Hz	Sum of "DL noise level" + "DUT Thermal noise level" + "SNR degradation by Butler Matrix"
DL noise level:	-129.91 dBm/Hz	MT8000A DL Level – 40 dB, for EVM 1% case
DUT Thermal noise level :	-159.3 dBm/Hz	This condition is defined in 3gpp TR38.810
SNR degradation by Butler Matrix :	9.13 dB	This value will be decided depends on Butler Matrix phase balance and condition number*.

Power [dBm]

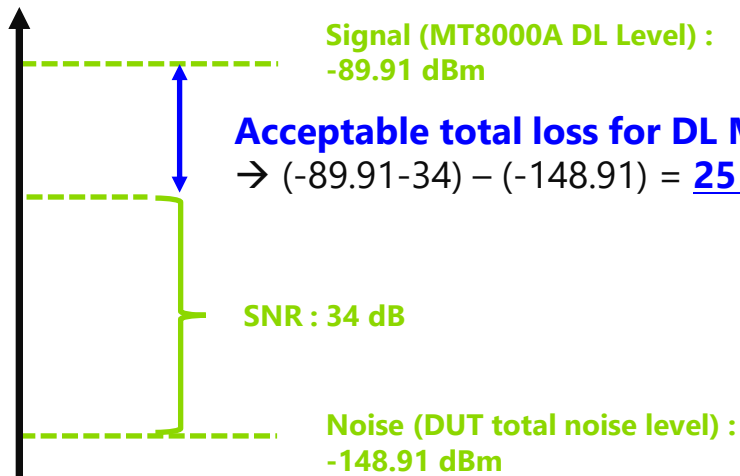

\* Condition number will be decided by Butler Matrix Input/Output selected port combination. To find good condition number, **Pathfinder tool** can be used.

Pathfinder tool for MA8118A will be available from MyAnritsu

# Cabling Advice Tool (Pathfinder)

The phase relationship of each antennas are important for MIMO. This tool show appropriate cable connection pattern(s) for maximizing Max Throughput testing by reducing re-cabling.

① Set 1 through 8 number for MT8000A and DUT ports

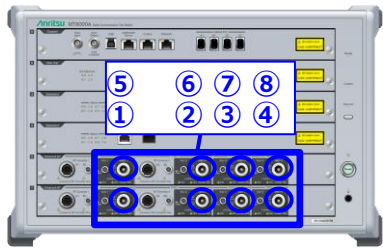

MT8000A

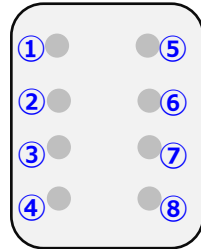

DUT

② Run Pathfinder, and set the following for each band

- MIMO type, testing band
- MT8000A port number(1~8) to be used for this band
- DUT port number(1~8) to be used for this band

Mode: Multiple  
New Profile\*  
Import Export  
Add UE Band

LinkType	Band	Input Antennas	Output Antenna
X	4x4	NR 41	1 2 3 4
X	4x4	LTE	5 6 7 8
X	4x4	42	1 2 3 4

MA8118A Inputs		MA8118A Outputs	
Device Antenna	MA8118A Port	Device Antenna	MA8118A Port
1	2R	1	1
2	4L	2	2
3	1L	3	3
4	2L	4	4
5	3L	5	5
6	1R	6	6
7	3R	7	7
8	4R	8	8

Suggest Connections



③ Click "Suggest Connection" button, then displays which Butler Matrix (MA8118A) ports should be connected to the MT8000A and DUT ports. (MT8000A port will be connected to MA8118A Inputs, DUT port will be connected to MA8118A Outputs)

# Appendix

# MA8114A Phase Table & Block Diagram

Reference Input port	Expected Values of Phase at Output(ports in degree)			
	1	2	3	4
1L	<b>-180</b>	<b>-135</b>	<b>-90</b>	<b>-45</b>
2L	<b>-135</b>	<b>0</b>	<b>-225</b>	<b>-90</b>
2R	<b>-90</b>	<b>-225</b>	<b>0</b>	<b>-135</b>
1R	<b>-45</b>	<b>-90</b>	<b>-135</b>	<b>-180</b>

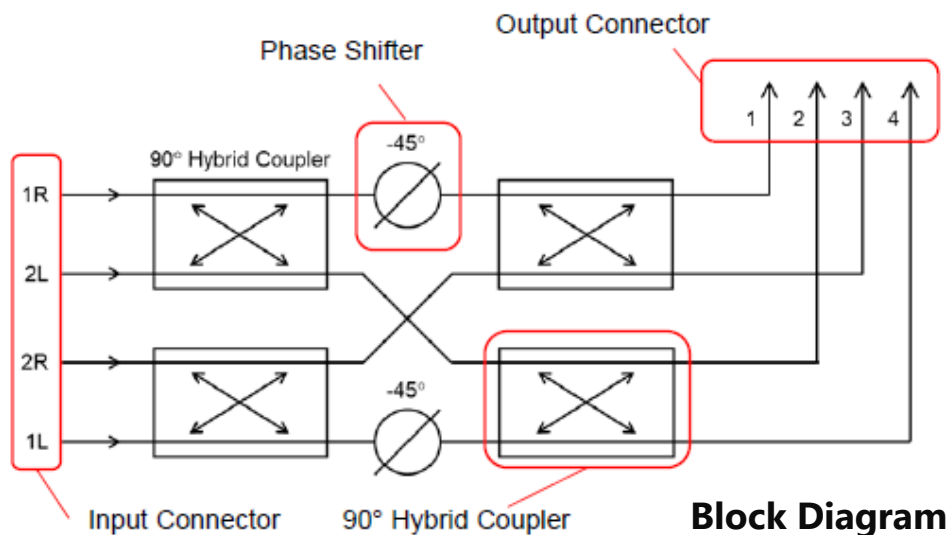
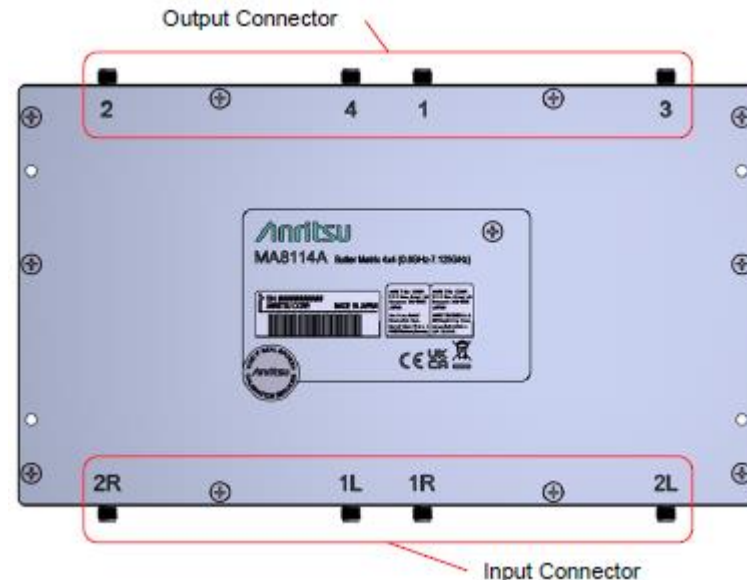

# MA8118A Phase Table & Block Diagram

Reference Input port	Expected Values of Phase at Output (ports in degree)							
	1	2	3	4	5	6	7	8
1L	-112.5	-135	-157.5	-180	-202.5	-225	-247.5	-270
2L	-112.5	-180	-247.5	-315	-22.5	-90	-157.5	-225
3L	-135	-247.5	0	-112.5	-225	-337.5	-90	-202.5
4L	-180	-337.5	-135	-292.5	-90	-247.5	-45	-202.5
4R	-202.5	-45	-247.5	-90	-292.5	-135	-337.5	-180
3R	-202.5	-90	-337.5	-225	-112.5	0	-247.5	-135
2R	-225	-157.5	-90	-22.5	-315	-247.5	-180	-112.5
1R	-270	-247.5	-225	-202.5	-180	-157.5	-135	-112.5

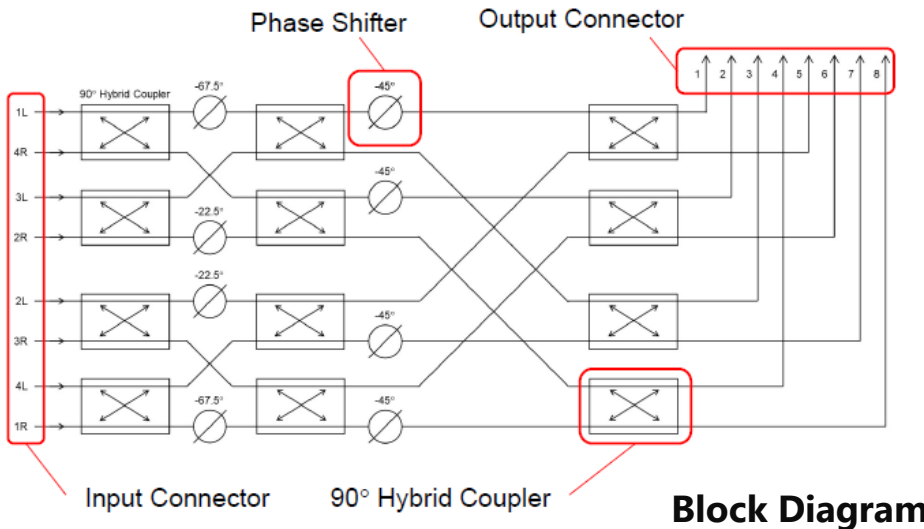
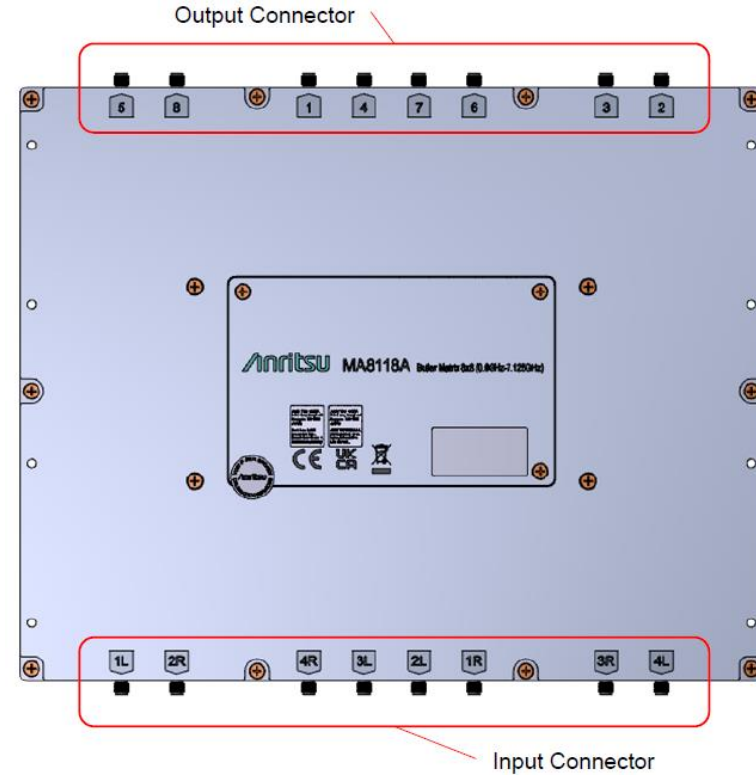

Block Diagram

The Anritsu logo is displayed in a bold, teal, sans-serif font. Below it, the tagline "Advancing beyond" is written in a smaller, black, sans-serif font. The background features a light green gradient with several curved, parallel lines in shades of green and yellow on the right side.

# Anritsu

Advancing beyond